



# EPROPULSION ELECTRIC BOATING

**2023** 11 Years of Innovative Electric Marine  
Propulsion Systems and Services





# CONTENTS

---

<i>Why Electric</i>	<i>P.04</i>	<i>I-Series</i>	<i>P.38</i>
<i>Who We Are</i>	<i>P.06</i>	<i>H-100</i>	<i>P.42</i>
<i>Partnership</i>	<i>P.14</i>	<i>Pod Drive Series</i>	<i>P.46</i>
		<i>E-Series Lithium Battery</i>	<i>P.48</i>
<i>Our New Product Line</i>	<i>P.16</i>	<i>G102-100 Lithium Battery</i>	<i>P.54</i>
<i>Evo Upgrade</i>	<i>P.20</i>	<i>Vaquita Motor</i>	<i>P.56</i>
<i>Product Range</i>	<i>P.24</i>	<i>Accessories</i>	<i>P.60</i>
<i>Versatile Applications</i>	<i>P.25</i>		
		<i>Community Engagement</i>	<i>P.62</i>
<i>Spirit Series</i>	<i>P.26</i>	<i>ePropulsion Owner Group</i>	<i>P.64</i>
<i>Navy Series</i>	<i>P.34</i>	<i>Ordering Information</i>	<i>P.65</i>

# Why Electric



## Better Experience

---

### Quiet

It's virtually silent. Perfect for not spooking fish when you are fishing.

### Clean

No messy fuel or oil leaks, and therefore no greasy stains on your hands, car trunk or boat.

### Exhaust-Free

Keeping you, your family and friends safer and healthier.

---



## Easier Operation

---

### Reliable

The efficient and innovative motor structure means there are fewer moving parts - making it reliable and robust.

### Digitization

Electric start and digital control with real-time operational data available.

### Low Maintenance

Significantly lower maintenance required than combustion engines. Maintenance-free on direct drive models.

---



## Kinder to the Earth

---

### Renewable Energy Sources

Recharge with hydrogeneration, wind turbine and solar panel.

### Cost Effective

Save on fuel and maintenance costs which also creates more value to commercial boats over the long-term.

### Environmentally Friendly

Enables boaters to access waters where combustion engines are banned.

---

# Who We Are

## Where we started

The idea was first started as a research project in the Hong Kong University of Science and Technology, a beautiful higher education institute located just by the bay and well-known for the breathtaking sea view. Out of the love for water sports and the ocean and a firm belief that ground-breaking electric engines and an innovative user-experience will accelerate human's transition into clean energy in the marine environment and beyond, four entrepreneurial engineering students started up the company ePropulsion. This young company was born to be an innovator and a change-maker with a strong drive to reconnect people with nature through better, smarter and cleaner inventions.

## Where we are now

Growing from humble beginnings in 2012 to now a global leader in marine electric propulsion systems and services with a distribution network across over 60 countries and areas to date, and a workforce of over 350 around the globe, we are proud of the achievements we have made for the past ten years in driving the world's transition to electric boating. The brand is now recognized across the world for exceptional product quality, performance and technological innovation.

We will continue to pioneer new technologies as we move towards an exciting future.

## We pride ourselves on being an innovator and market challenger

We have an established track record of cutting-edge design based on award-winning research and development. This led to the first introduction of a brushless direct drive electric outboard motor and the first incorporation of hydrogeneration capabilities into electric outboards in the industry.

ePropulsion has fast become a force to be reckoned with in the electric propulsion market, seeing the brand win significant market share across the world – which continues to grow.

The industry demand for ePropulsion products is set to propel even further.

# Our Strengths

## Product Innovation

We constantly listen and talk to our customers, to fully understand their needs and to use their knowledge and feedback to help drive the continual innovation of our products. We are proud to say the end result is significantly better user experience than combustion engines or most comparable products.

## Competitive Pricing

ePropulsion is helping to rapidly accelerate the transition to electric propulsion systems in boating and sailing communities. To help this transition, we supply products at competitive prices to help customers make the switch from combustion engines.

## Quality Excellence

We collect and analyze quality-related historical and real-time data of our products and machinery in our manufacturing plant. We then utilize that data to build quality profiles and models. We have also built a QA laboratory which has 25 different testing capabilities that can simulate all extreme working and transportation conditions.

## Fast Customer Service

Our wide and well-established network of dealers across 60+ countries and areas ensures that our customer support is fast and responsive. We are always there for you when you need it – making ownership of our products easy and hassle-free.

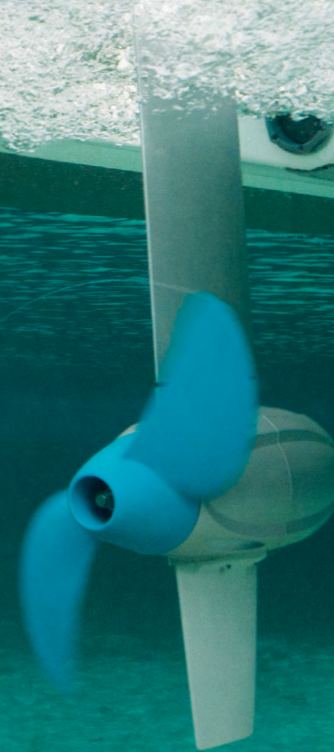

# Technology Pioneer

ePropulsion has a strong engineering culture - it is in our DNA. Our engineers enjoy the toughest challenges and developing solutions and products that are truly innovative and easy-to-use.



## Industry Leading

### 2022

**The first electric inboard motors integrated with boating IoT**

Pioneering smart solutions for boating electrification.

Model: I-10 | I-20 | I-40 | H-100



### 2021

**The first hydroelectric outboard motors**

Hydrogeneration function makes sailing more sustainable.

Model: Spirit 1.0 Evo | Navy 3.0 Evo | Navy 6.0 Evo



### 2014

**The first brushless direct drive electric outboard motor**

A direct drive outboard motor can be quiet, reliable and maintenance-free.

Model: Spirit 1.0



## Engineering Innovation

### eSSA

#### ePropulsion Smart System Architecture (eSSA)

ePropulsion's most advanced hardware and software technology. It features a smart and modular design to deliver safe and reliable performance thanks to its fault diagnosis system and full redundancy design. The modular design also allows for a number of different batteries to be selected depending upon range requirements, providing a high level of flexibility.

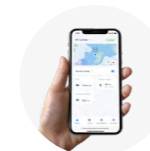

#### Boating IoT

ePropulsion Connectivity Service is a value-added service enabling boat owners and fleet managers to communicate with their boats securely and reliably. It allows users to access cloud-based connectivity services without the need for additional accessories.



#### Floating Battery

The Spirit battery is the first floating battery on the market. With the waterproof and unsinkable design, users are worry-free and will never lose a battery overboard again.

# Customer Satisfaction Matters the Most



“ Our focus every single day is to continually improve all aspects of our customer experience. ”

— Danny Tao  
ePropulsion CEO & Co-Founder

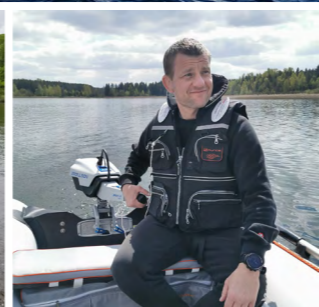

## Customised Solutions

### Spirit 1.0 RS21 Drive

“ You can usually expect some teething issues with new boat designs but the ePropulsion solution has been seamless. Their system works perfectly and is one of the easiest systems we fit on the boat, even when we are retrofitting on boats away from the factory. It's silent, robust and really complements the overall quality of the RS21 package.”

— Alex Southon, RS Sailing CEO 

On June 15, 2019, ePropulsion signed a deal to supply fully-integrated propulsion systems to RS Sailing. The new supply contract covers a bespoke mounting arrangement and integration of ePropulsion's Spirit 1.0 electric motor into a flush-fitting retractable electric drive system onboard the first 60 boats in RS Sailing's fleet of exciting new RS21 keelboat day racers.

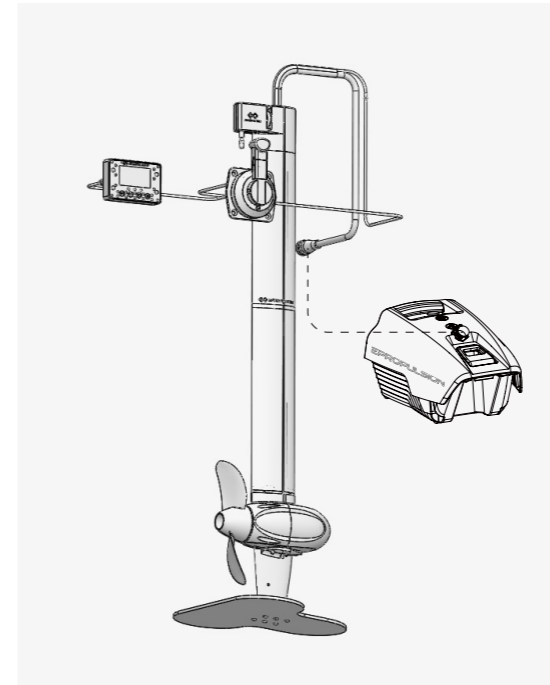

# Partnering with SailGP to Advance Global Adoption of Clean Energy

SailGP is an adrenaline-fuelled global sailing competition and the first climate-positive sports and entertainment property with the goal of accelerating the transition to clean energy.

With a shared mission for more sustainability, ePropulsion is working in partnership with SailGP to provide 11 electric outboard motors for the league's event support tenders in Season 2 and Season 3. Both ePropulsion Spirit and Navy motors were selected to power SailGP Inspire support boats, SailGP's community, education and outreach initiative.

During Season 2, ePropulsion supported SailGP to establish a comprehensive fleet monitoring program. The continuous partnership helped SailGP reduce its support boat fleet emissions by 10% per average event.

ePropulsion and SailGP will continue to work together to help revolutionize the sports and entertainment industry focusing on an acceleration towards clean energy.



## SailGP Support Boat Fleet Powered By



Spirit 1.0 Plus / 3HP



Navy 3.0 Evo / 6HP



E80 Battery / 4096 Wh

“ We are excited to work with like-minded partners that share our vision of accelerating the transition to clean energy. Our partnership with ePropulsion is the first of many steps to meet our ambitious target of being fully powered by nature on-water by 2025 and is a great example of how, through technology and innovation, we can help create a better planet. ”

- Fiona Morgan, SailGP Global Director of Purpose and Impact



# Introducing the ePropulsion Electric Inboard Motor Line

ePropulsion launched two pioneering electric inboard motor series, the I-Series and H-Series in 2022. The new electric inboard motor line supports the electrification of pre-owned combustion boats and the manufacturing of new and more sustainable boats, providing ideal solutions for both leisure marine and commercial users.

## I-Series Electric Inboard Motor

Highly-integrated Compact Smart Connectivity

The I-Series Electric Inboard Motor is developed to enable users to enjoy the changes brought about by the electrification and intelligence of small and medium-sized boats.

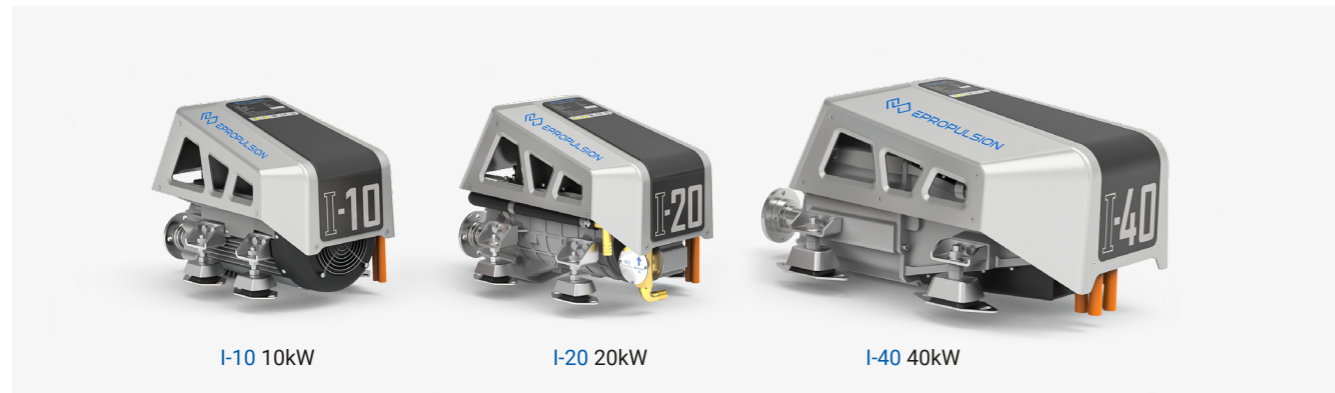



## H-100 Electric Inboard Motor

100 kW Modular Design OEM Capability

The H-100 is a 100 kW electric inboard motor, engineered for larger sailing boats and motor vessels between 60 and 100' (18-30m) with a full displacement up to 200 tons, that delivers high performance with less noise, fewer vibrations and zero exhaust fumes.



 Smaller size, better space utilization

 Modular design, high expandability

 Boating IoT system, smart and customizable

# Build on the state-of-art eSSA

Underpinned by the ePropulsion Smart System Architecture (eSSA), the I-Series features a smart and modular design to deliver safe and reliable performance and also supports the integration of ePropulsion Connectivity Service and ADAS.



Smart



Modular



Safe and Reliable

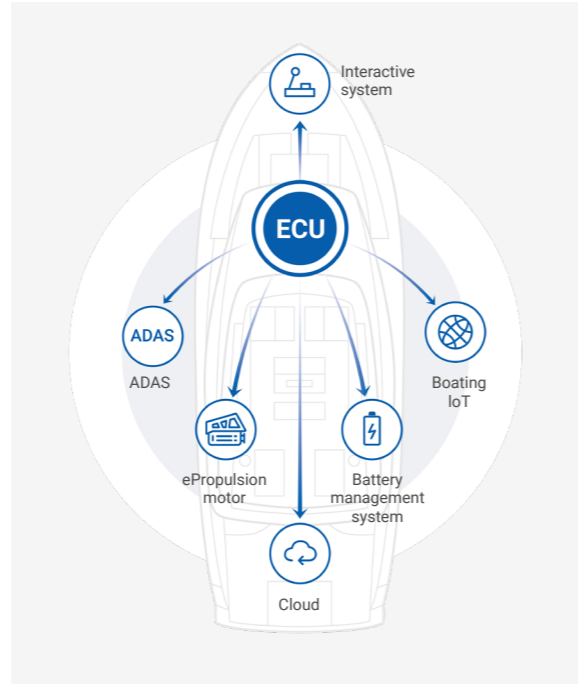

# Integrated with boating IoT

ePropulsion Connectivity Service is a value-added service enabling boat owners and fleet managers to communicate with their boats securely and reliably. It allows users to access cloud-based connectivity services without the need for additional accessories.

ePropulsion Connectivity Service

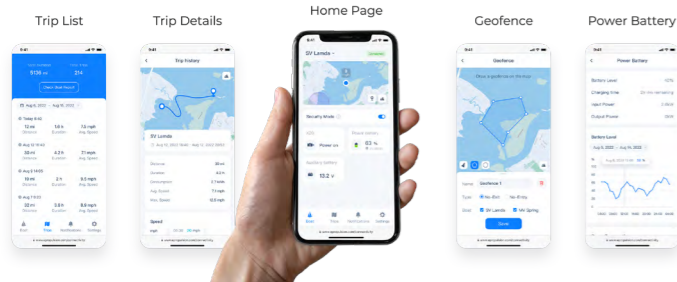

# Key Features



## Remote data access

You can check all real-time data, such as location, speed, battery level, remaining charging time, etc.



## Remote monitoring

Notify users when boats break geofences, exceed speed limits and have suspicious location changes.



## Trip tracking

Automatically create boating trips with route playback and trip log.



## Shared accounts

Invite other people to share access to real-time status, past activities and reports.



## Guest authorization

Remotely authorize guests to power on and operate ePropulsion system with limited permissions.



## Report generation

Automatically create boat reports and fleet reports to summarise all boating activities.

# EVO UPGRADE SMARTER TECHNOLOGY AND BETTER USER EXPERIENCE

In 2021, ePropulsion launched seven all new Evo models. This is the most important product upgrade since the company delivered the first Spirit 1.0 seven years ago. The Evo upgrades are as a result of product feedback from our enthusiastic customers which has enabled us to closely refine and improve our range.



## Hydrogeneration

ePropulsion's Spirit Evo and Navy Evo are the first-ever hydroelectric outboard motors. It's a remarkable green innovation, especially for the sailing community.

**Benefit:** Hydrogeneration makes sailing trips even more environmentally friendly and sustainable. Much of the time you don't even need to turn on the generator on a sailboat.



## Safety Wristband

In case of a man overboard situation, the safety wristband immediately shuts down the motor. Each Evo motor can connect with up to 8 safety wristbands.

**Benefit:** The safety wristband keeps everyone onboard safe, not just the operator attached to the kill switch. This function also keeps you safe when you're alone and not in close proximity to the kill switch.



## 48V Motor Architecture

Each Evo model in the range has been developed on a 48V voltage platform with the same systems protocol.

**Benefit:** There is excellent compatibility between Evo outboards, Evo pod drives, E-Series batteries, and Evo controls - and therefore flexibility to configure a system that fits your needs.



ePropulsion offers excellent compatibility between different control systems. They have all been developed under same system platforms, and work seamlessly with Evo motors and other Evo components.



### Evo Tiller

Ergonomic and removable design  
3.4-in integrated display with backlight



### Evo Remote Control

Wireless connection  
3.4-in integrated display with backlight



### Evo Side Mount Control

4.3-in separate display with backlight  
False triggering protection



### Evo Dual Remote Control

Sync Mode  
Docking Mode  
4.3-in separate display with backlight



### Safety Wristband

Easy-to-use and additional safety.

- Man overboard protection
- Wireless connection
- Waterproof IP67
- Max connection up to 8 wristbands per motor

To make your boating experience even safer, ePropulsion has launched its wireless safety wristband. In case of a man overboard situation, the safety wristband immediately shuts down the motor. Each Evo motor can connect with up to 8 safety wristbands. This function also keeps you safe when you're alone and not in close proximity to the kill switch. You, your families, friends, and dogs are all protected.

\* Safety wristband is compatible with Evo tiller and Evo remote control, not compatible with Evo side mount control or Evo dual control.



### Information Display

Keeping you informed.

- Battery level
- Remaining runtime
- Remaining distance\*
- Realtime power
- Error codes
- Speed\*
- Realtime voltage
- Hydrogeneration power / status
- Metric and imperial conversion
- Safety wristband connection status

\* Not available on Spirit Series or Pod Drive 1.0 Evo.

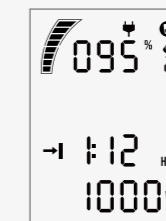

# Product Range

## Outboard

Spirit 1.0 Plus  
1 kW / 3 HP



Spirit 1.0 Evo  
1 kW / 3 HP



Spirit 1.0 Evo Remote  
1 kW / 3 HP



Navy 3.0 Evo  
3 kW / 6 HP



Navy 6.0 Evo  
6 kW / 9.9 HP



## Inboard

H-100  
100 kW



## Inboard

I-10  
10 kW



I-20  
20 kW



I-40  
40 kW



## Pod Drive

Pod Drive 1.0 Evo  
1 kW / 3 HP



Pod Drive 3.0 Evo  
3 kW / 6 HP



Pod Drive 6.0 Evo  
6 kW / 9.9 HP



## Control

Evo Tiller



Evo Remote Control



Evo Side Mount Control



Evo Dual Remote Control



Smart Throttle Smart Display 5"



## Battery

Spirit Battery Plus\*  
1276 Wh / 48 V



## Battery

E40 Battery  
2048 Wh / 48 V



E80 Battery  
4096 Wh / 48 V



E175 Battery  
8960 Wh / 48 V



E60 Battery  
3072 Wh / 48 V



E163 Battery  
8345 Wh / 48 V



G102-100 Battery  
10240 Wh / 96 V



\* Also applicable to Spirit 1.0 Evo & Spirit 1.0 Evo Remote

# Versatile Applications

## For Sailboats

ePropulsion electric outboards enable one-design sailboats to leave and return to the marina quick, silent and maneuverable. Owners of daysailers and small cruising sailboats love pod drives because they are space-saving, quiet and vibration-free. The hydrogeneration and solar charging also allow sailors to travel further and sail sustainably.

## For Fishing Boats

Fishing quiet is important. Our electric outboard motor is so quiet it won't spook the fish. In addition, electric outboards are super efficient at trolling speed and you can go fishing all day long without worrying about the run-time. Ideal for both freshwater and saltwater and perfect for jon boats, aluminum fishing boats, bass boats and fishing pontoons.

## For Work Boats

The electric outboard motor has a simple structure and fewer components than gas engines. It offers a more reliable solution while requiring minimum maintenance. Work boats, commercial boats and rental boats can go further for longer. The quiet and exhaust-free experience also makes passengers comfortable onboard.

## For Dinghy and Tenders

With our long-range batteries and digital display, boaters can leave their "run-time" worries on the dock. The integrated and minimum maintenance designs are time- and money-saving, making our electric outboard motors perfect for dinghy, inflatable boats, tender boats and small sailboats.



# Spirit Series

3HP / 1276Wh



Spirit 1.0 is ePropulsion's best selling series. It's designed for portability with a 1276 Wh integrated lithium battery.

## Specs



	Spirit 1.0 Plus	Spirit 1.0 Evo	Spirit 1.0 Evo Remote
Power	1000W / 3HP		
Battery Capacity	1276 Wh		
Motor Weight*	10.6 kg / 23.4 lbs	11.3 kg / 24.9 lbs	10.9 kg / 24 lbs
Battery Weight	8.7 kg / 19.2 lbs		
Charging Time	3.5 Hrs (Fast charger) / 8.5 Hrs (Standard charger)		
Battery Life*	500 cycles at 80% DOD		
Shaft Length	XS: 52.5 cm / 20.7 inches S: 62.5 cm / 24.6 inches L: 75 cm / 29.5 inches	S: 62.5 cm / 24.6 inches L: 75 cm / 29.5 inches	
Input Voltage	39V - 60V		
Propeller RPM	1200 RPM		
Propeller	11" x 5.8" 2-blade composite propeller		
Trim / Tilt Angle	0°, 7°, 14°, 21° / 70°	0°, 7°, 14°, 21° / 85°	0°, 7°, 14°, 21° / 85°
Hydrogeneration	✗	✓	✓
Safety Wristband	✗	✓	✓
Display Backlight	✗	✓	✓

\*The weight is measured by short shaft. The weight of Spirit 1.0 Evo Remote excludes the control.  
\*Battery life is based on laboratory testing. Actual battery life may vary depending on actual operational environment and usage conditions.

# Taking you Further

## Performance & Range

Power (Watt)	Speed (mph / kph)	Running Time (hh:mm)	Range (mile / km)
35	2.2 / 3.5	36:25	80 / 129
65	2.7 / 4.3	19:35	53 / 85.3
125	3.5 / 5.6	10:00	35 / 56
250	4.4 / 7.1	5:00	22 / 35.5
500	5.3 / 8.5	2:30	13.3 / 21.3
750	5.7 / 9.2	1:40	9.5 / 15.3
1000	6.2 / 10	1:15	7.8 / 12.5

\*The performance data is based on a 12-foot aluminum boat with one person and one Spirit Battery Plus in calm lake water. The actual speed, range and running time may vary because of different boats, load, weather, etc.

# Sailing Enthusiasts Love Spirit Series



We jumped at the chance to test out ePropulsion Spirit 1.0 Evo electric outboard. Being able to use our dinghy without any petrol and charge the engine from our solar panels indefinitely was pretty intriguing. No smelly jerry cans on deck, no noisy engine that breaks down every so often, that sounded good.

- Sailing Learning By Doing

Follow Sailing Learning By Doing:

- Sailing Learning By Doing
- Sailing Learning By Doing
- @vernondeck



Watch the review video here

## One Charge to Go 22 Miles

### Seattle

Pike Place Market to Golden Gardens Park Round Trip / 18 Miles

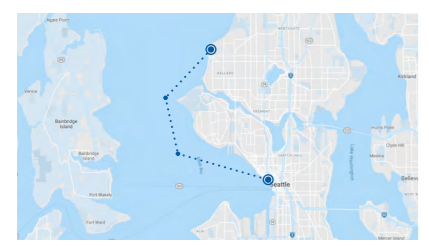

### Miami

Miami Seaquarium to North Beach Round Trip / 17.6 Miles

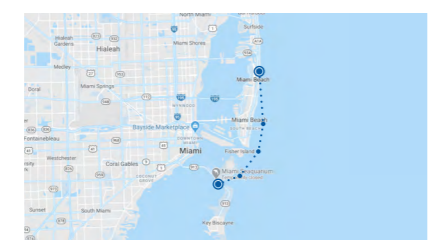

### San Francisco

Golden Gate Bridge to Alcatraz Island to Pier 39 Two Laps / 16 Miles

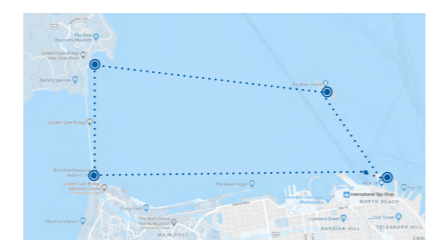

“We’ve had our ePropulsion Spirit 1.0 for three years now, and we absolutely loved it. It has been 100% maintenance-free the entire time. We haven’t had to do anything. In our old outboard, we always had this feeling of dread. But with the ePropulsion, there’s never a feeling of uncertainty; it’s a feeling of reliability. Because every time I press the power button and twist the throttle and goes. Like there’s nothing else to it if only everything on the boat worked that way. Not having to worry about getting fuel, not having to store fuel, not having to fix anything on it. It’s such an easy thing to deal with. It warms my heart.

- Sailing Soulianis

Follow Sailing Soulianis:

- Sailing Soulianis
- Sailing Soulianis
- @sailingsoulianis



Watch the review video here





## Long Range

Thanks to the 1276Wh large battery, Spirit 1.0 Plus / Evo has longer range than other gasoline outboards and electric outboards.

Spirit 1.0 Plus / Evo

75 min

Average 3HP electric outboard

50 min

A FourStroke 3.5HP\*

48 min

\* The runtime of the above FourStroke 3.5HP is measured with the 0.3 gal (1.1 L) internal fuel tank.

## Hydrogeneration

ePropulsion supplies electric outboard motors that have hydrogeneration functionality on the market. Sailors will love this new feature as it makes sailing more sustainable.

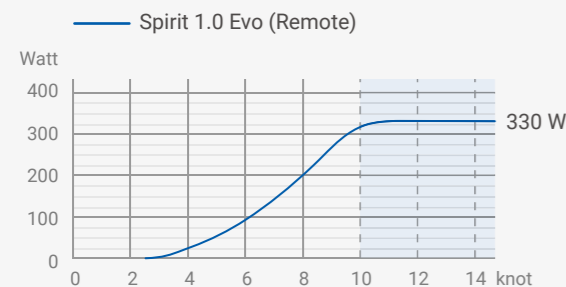

\* Spirit 1.0 Evo outboard can drive the propeller to charge the battery (only the ePropulsion battery) through water flow when certain conditions are met (please refer to the user manual in the download center for the required conditions).

\* The hydrogeneration data is based on real tests with the anti-ventilation plate installed.

## Design

**1 1 1 Magnetic kill switch**  
In case of emergency, pull out the switch to immediately stop the motor.

**2 Removable tiller**  
Quick to install or pack your Spirit. Flexibility in carrying the tiller separately.

**3 3 3 Gauge display**  
Access to battery level, remaining runtime, input power, and voltage, etc.

**4 4 4 Charging port**  
It works with both AC charger and solar charger.

**5 5 5 Durable metal connector**  
Made of stainless steel and processed by PVD technology.

**6 6 Safety wristband**  
In case of man overboard, it immediately shuts down the motor.

**7 Evo side mount control**  
This smooth single lever control works together with a 4.3-inch gauge display.

**8 Evo remote control**  
Compact, economical and integrated with a 3.4-inch display.

**9 9 9 Battery pull latch**  
Making battery installation easy and quick.

**10 Steering tube**  
Works with a mechanical or hydraulic steering helm and the steering link arm.

**11 11 11 Anti-corrosion coating**  
Anodized coating and powder coating which protects the base material from corrosion.





# Spirit Battery



## Floating Battery

Removing your battery to take it to and from your boat could mean accidentally dropping it in the water. That's why we developed the Spirit battery to float! You will never lose a battery overboard again.



## Solar Charging

Using a solar panel, you can charge your battery up to 180 W while in use. On a sunny day, your battery could last all day if used at the economical power level. An additional benefit is that the solar panel is lightweight and foldable. An additional solar charger is required for this functionality.



## Spirit Battery Power Output Set

In a non-deep-sleeping mode, extract the major power from the Spirit battery to power other electronics on board, with a display of current battery level and error code. (Note: the DC-DC connect to this needs to be purchased separately.)



## Effortless Battery Replacement

To extend the range even further, you can purchase an additional Spirit battery. The battery is secured by a pull latch and changing out your battery usually takes less than 30 seconds. The process is very easy and it is good to know that storing your Spirit battery is safer than other fuels such as petrol/gasoline.

# Navy 3.0 Evo / 6HP

# Navy 6.0 Evo / 9.9HP



Navy series electric outboard motors deliver simple and efficient power at 6 HP or 9.9 HP depending on the model. Sleek, easy to use and eco-friendly, these outboards will be a staple of your boating experience for years to come.

## Features

### Brushless Direct Drive Motor

Navy series is a direct drive electric outboard at this power range. They're made of fewer moving parts, no gearbox required. This means less vibration, noise-free and high reliability.

### Hydrogeneration

ePropulsion supplies electric outboard motors that have hydrogeneration functionality on the market. Both Navy 3.0 Evo and Navy 6.0 Evo feature hydrogeneration, a new feature loved by sailors.

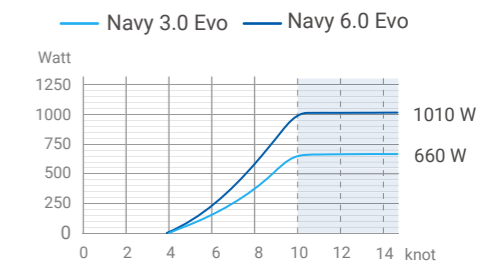

\* Navy 3.0 Evo and Navy 6.0 Evo outboards can drive the propeller to charge the battery (only the ePropulsion battery) through water flow when certain conditions are met (please refer to the user manual in the download center for the required conditions).

## Specs



	Navy 3.0 Evo	Navy 6.0 Evo
Power	3 kW / 6 HP	6 kW / 9.9 HP
Operation Voltage	48V (Input Range 39V to 60V)	
Outboard Weight*	24.3 kg / 53.6 lbs	36 kg / 79.4 lbs
Shaft Length	S: 63.4 cm / 25 inches L: 75.9 cm / 29.9 inches	
Static Thrust	590 N / 132.6 lbs	1243 N / 279.4 lbs (13.4" x 8.5" composite propeller)
Propeller RPM	2300 RPM	1500 RPM
Propeller	10.2" x 6.7" 2-blade composite propeller	12.6" x 10.8" 3-blade composite propeller 13.4" x 8.5" 3-blade composite propeller 12.6" x 8.7" 3-blade aluminum propeller (optional)
Trim / Tilt Angle	0°, 5°, 10°, 15° / 60°	
Hydrogeneration*	✓	✓

\* The outboard motor weight is measured with the short shaft version, excluding the control weight.

\* The hydrogeneration data is based on real tests with the anticavitation plate installed. Navy 6.0 Evo is tested with a 13.4" x 8.5" three-blade composite propeller.

# Taking you Further

## Performance & Range

Navy 3.0 Evo (Watt)	Speed (mph / kph)	Runtime (hh:mm)	Range (mile / km)	Navy 6.0 Evo (Watt)	Speed (mph / kph)	Runtime (hh:mm)	Range (mile / km)
300	3.7 / 6	13:20	49.3 / 79.3	500	4 / 6.5	18:00	72 / 116
550	4.7 / 7.5	7:25	35 / 56.3	1000	5 / 8	9:00	45 / 72
1000	5.3 / 8.6	4:00	21.2 / 34.1	2000	6.7 / 10.8	4:30	30.2 / 48.6
1500	6 / 9.7	2:40	16 / 25.7	3000	8 / 13	3:00	24 / 39
2000	6.3 / 10.2	2:00	12.6 / 20.4	4000	11.5 / 18.5	2:15	25.9 / 41.7
2500	8 / 12.8	1:35	12.7 / 20.5	5000	13.5 / 21.8	1:50	24.7 / 39.8
3000	10.2 / 16.4	1:20	13.6 / 21.9	6000	15 / 24.3	1:30	22.5 / 36.5

\*The performance data is based on a 12-foot aluminum boat with one person, powered by one Navy 3.0 Evo and E80 battery / Navy 6.0 Evo and E175 battery in calm lake water. The actual speed, range and running time may vary because of different boats, load, weather, etc.

# Navy 6.0 Evo Brings New Excitement

## Highfield 380CL + Navy 6.0 Evo



“ I’m not used to feeling the water cavitating on the boat because usually you just feel the vibration of an engine. With Navy 6.0 Evo, it’s so quiet and so bizarre! It’s just the water under the hull. ”

- Captain Rick Moore

## Go with Navy

**Seattle**  
Pike Place Market to Golden Gardens Park

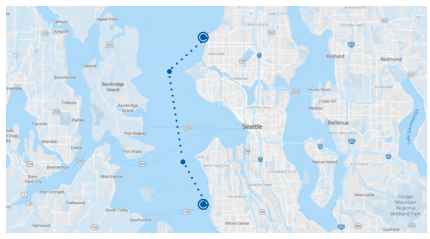

Navy 3.0 Evo + E80 = Round Trip / 24 Miles  
Navy 6.0 Evo + E175 = Three Trips / 36 Miles

**Miami**  
Miami Seaquarium to North Beach

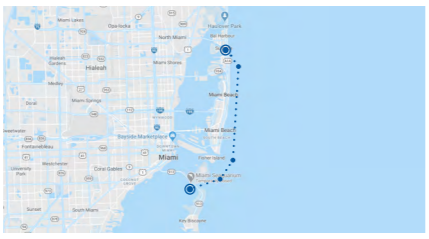

Navy 3.0 Evo + E80 = Round Trip / 22 Miles  
Navy 6.0 Evo + E175 = Three Trips / 33 Miles

**New York**  
Statue of Liberty to New York Aquarium

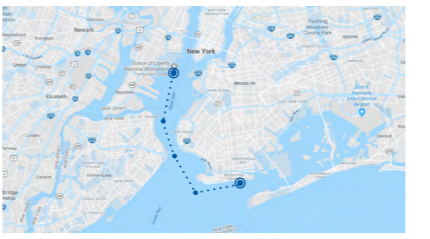

Navy 3.0 Evo + E80 = Round Trip / 22 Miles  
Navy 6.0 Evo + E175 = Three Trips / 33 Miles

Captain Rick Moore has been sailing for over 20 years. He has always been led by his passion and the wind, and has been sharing his sailing and adventure stories for 15 years on YouTube channel Sophisticated Lady.

Follow Captain Rick Moore:  
[@Captain Rick Moore](#)  
[Sailing Sophisticated Lady](#)  
[@sailingsophisticatedlady](#)

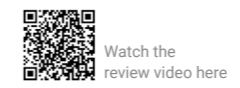

Watch the review video here



# I-Series New Electric Inboard Motor

Enable users to enjoy the changes brought about by the electrification and intelligence of small and medium-sized boats.

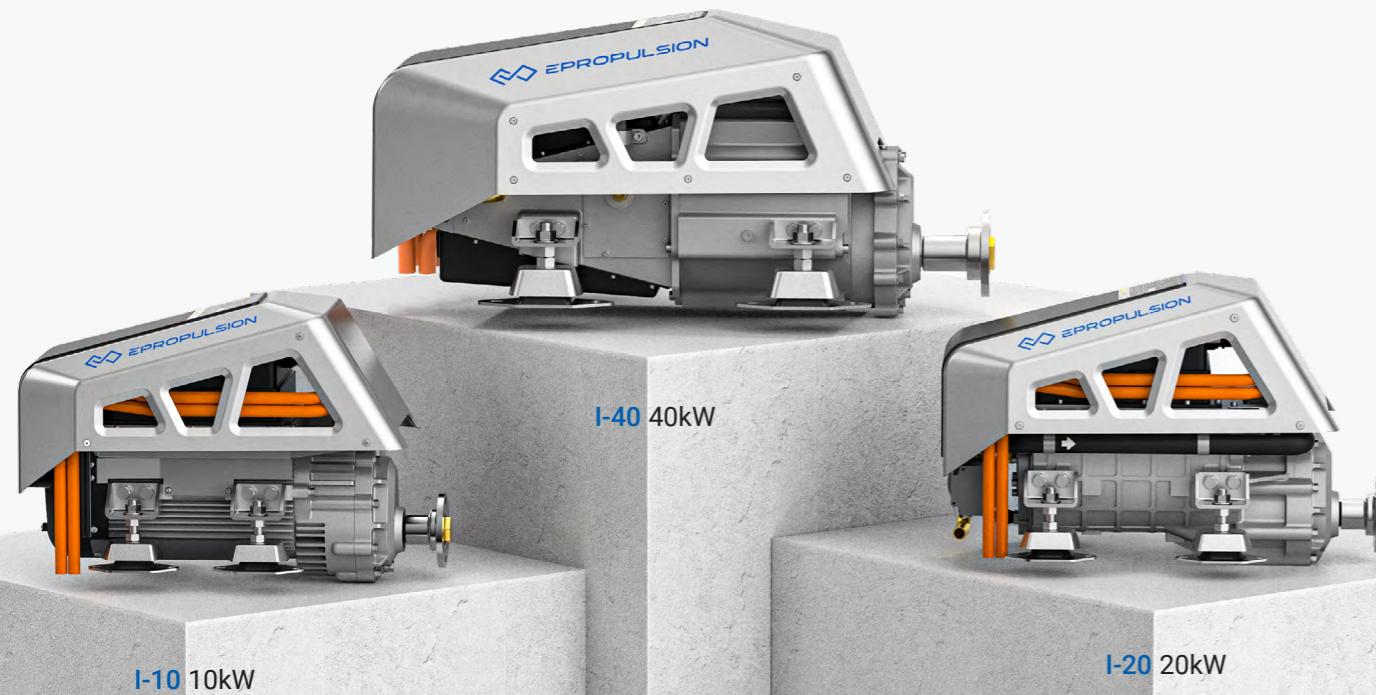

## Overview

ePropulsion I-Series electric inboard motor is an environment-friendly electric inboard motor series packed with innovative technology, smart features and human operation design. Underpinned by the highly integrated and modular ePropulsion Smart System Architecture and the IoT connectivity service, it provides users with an easy-to-use, intelligent, safe and reliable experience unlike any other. It is ideal for leisure marine and commercial applications on small and medium size boats including cruisers, workboats, ferries, water buses, monohull sailboats and catamaran sailboats, etc.

## Features



Efficient



Clean



Quiet



Hydrogeneration



### Compact and Integrated

A compact design that integrates five functional modules of motor, gearbox, motor controller, system control unit and cooling system into a small space.



### Space-saving

Take up 60% less space than typical combustion engines and reduce engine room size.\*



### Lighter weight

65% less weight than typical combustion engines and 30% lighter than electric inboard motors of similar range.\*



### Easy to install

Internal wiring has been connected before delivery, providing customers with an out-of-the-box experience.



### Easy to maintain

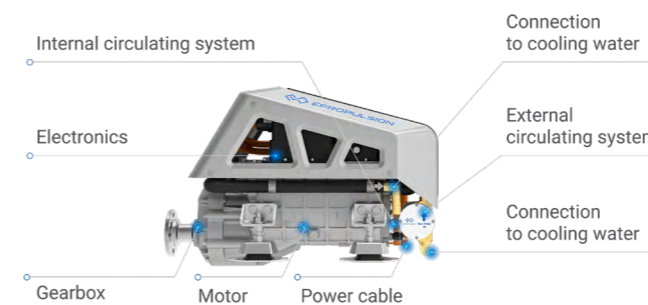

The technology and the design of the interfaces significantly lower the maintenance required than combustion engines.

\* Under the same input power.



## Build on the state-of-art eSSA

Underpinned by the ePropulsion Smart System Architecture (eSSA), the I-Series features a smart and modular design to deliver safe and reliable performance and also supports the integration of ePropulsion Connectivity Service and ADAS.

-  Smart
-  Modular
-  Safe and Reliable

## Specs



Model	I-10	I-20	I-40
Input power	10 kW	20 kW	40 kW
Input voltage	86~115 VDC	86~115 VDC	86~115 VDC
Weight	45 kg	49.5 kg	85 kg
Dimensions (L x W x H)	565 x 295 x 380 mm	580 x 330 x 380 mm	790 x 450 x 410 mm
Cooling method	Air cooling	Water cooling (air cooling optional)	Water cooling (air cooling optional)
Rated rotational speed	1500 rpm	1500 rpm	1000 rpm
Operation and interaction	Throttle & display	Throttle & display	Throttle & display
Connectivity service	Support	Support	Support

\* The specifications are for reference only.

## Integrated with boating IoT

ePropulsion Connectivity Service is a value-added service enabling boat owners and fleet managers to communicate with their boats securely and reliably. It allows users to access cloud-based connectivity services without the need for additional accessories.

## Accessories

### Standard accessories

The Smart Throttle and Smart Display 5" provide excellent user experience in controlling and monitoring. The Smart Throttle supports 3 mounting options for flexible installation. You could always find a best fit for your boat.

#### Smart Throttle



- ✓ Top or Side
- ✓ Single or Dual
- ✓ Portside or Starboard

\* More control methods are coming...

#### Smart Display 5"



- Aquatic scenes
- High security
- Intelligent diagnosis
- Local cloud interconnection
- Active interaction
- Data synchronization

External GPS Module, 4G Antenna, DC-DC, Busbar and Cable Kits are optional.

### OEM accessories upon request

Propeller, air-cooling, HVAC system, shaft and coupling, chargers and more to come...

# H-100 New Electric Inboard Motor

100 kW    Modular Design    OEM Capability



## Overview

The H-100 is a 100 kW electric inboard motor, engineered for larger sailing boats and motor vessels between 60 and 100' (18-30m) with a full displacement up to 200 tons, that delivers high performance with less noise, fewer vibrations and zero exhaust fumes.

## Specs

Rated Voltage	540 VDC	IP Rating	IP67
Rated Power	100 kW	Insulation Level	H
Rated Torque	797 Nm	Cooling Methods	Water Cooling
Rated Speed	1150 rpm	Operating Temperature	-25°C ~ +55°C
Rated Efficiency	96%	Dimensions	443 x 315 mm (17.4 x 12.4 in)

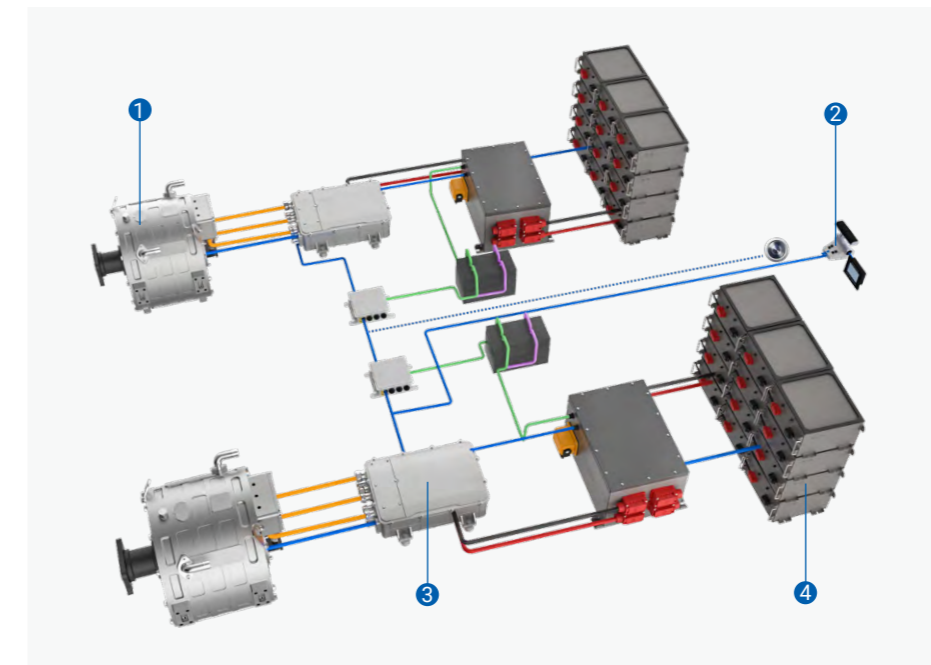

- ① H-100 electric inboard motor
- ② Remote control and display
- ③ Controller
- ④ Battery

# Features

## Smaller size, better space utilization

H-100 is about two-thirds lighter and 50% smaller than its diesel counterpart, providing installation flexibility and maximizing payload and passenger space. The flat wire motor increases slot fill by 25% and increases power density.

## Modular design, high expandability

H-100 electric inboard motor kit adopts modular design. The manufacturers can easily extend the range and power by adding motors, controllers and batteries, and having more flexibility. Different power combinations can be chosen according to different power and range requirements, which allows the H-100 to be more expandable.

## Optimum performance, pioneering technology

Equipped with pioneering permanent magnet motor technology, the H-100 gives its diesel counterparts a run for their money, achieving 2000 Nm maximum torque and delivering an impressive 96% efficiency, higher than the traditional 100 kW AC asynchronous motor.



## Boating IoT system, smart and customizable

The boating Internet of Things (IoT) system can be customized and developed to meet the customers' needs of remote monitoring and integrated management. Speed, power, track, mileage, safety alarm and other functions also can be customized and developed according to your requirements. Boat owners can use the web port to track their boats in real time and to realize integrated management.

## Safety and reliability

- IP67 waterproofing
- Anti-corrosion
- High accuracy position feedback
- High torque density
- Closed-loop cooling

# Accessories

## Custom-built Battery

Battery can be tailored to fit customers' needs. The battery power needs to be calculated and determined according to the range requirements. For a 100 kW electric inboard motor operating at full power for 1 hour, the propulsion system will need a 100 kWh battery which can be developed based on the provided specs.

System Rated Output Voltage	540 VDC	Discharge Temperature	-30°C ~ 60°C
System Output Voltage Range	487 ~ 604 VDC	25°C Cycle Life (80% DOD)	> 3500 times
Battery Capacity **	/	25°C Storage Life	> 8 years
Total System Energy **	/	Charging Temperature	0°C ~ 60°C

\* The battery specifications are based on a 100 kW electric inboard motor operating at full power for 1 hour. Actual performance parameters may vary depending on battery capacity.

\*\* Battery capacity and total system energy can be customized to fit customers' needs.

## Controller

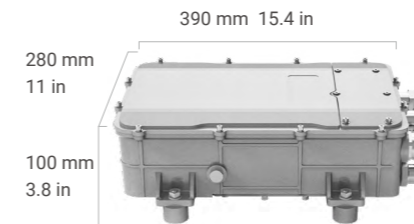

Logic Power Supply Range	9~16 V / 18~32 V	Rated Output Current	270 A
Rated Input Voltage	540 VDC	Maximum Efficiency	99%
Input Voltage Range	400 ~ 720 VDC	IP Rating	IP67
Rated Power	160 kVA		

## Remote Control and Display

- Single / dual remote control (Optional)
- Ergonomic design, good operating experience
- 4.3" display, user friendly interface



# Pod Drive Series

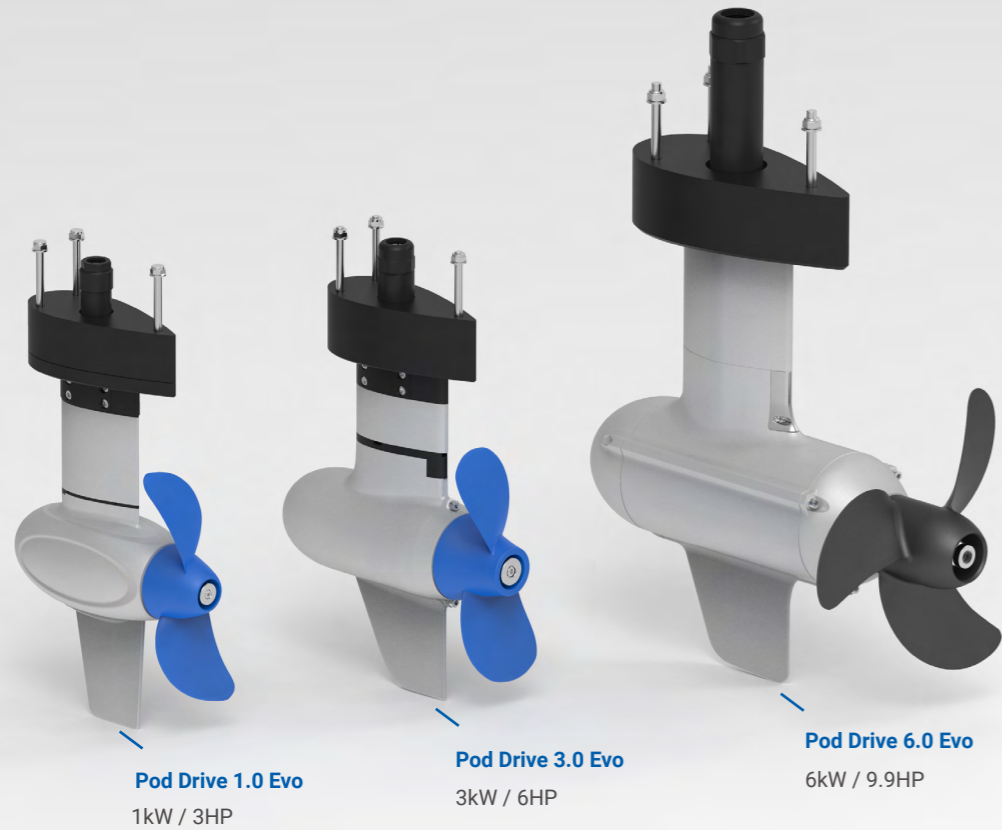

Space-Saving



Easy to Install



Quiet



Minimum Maintenance

## Hydrogeneration

Sailors will love the Evo series Pod Drive Series not just because they are lightweight and space-saving, but also because the hydrogeneration function brings more flexibility and sustainability to their sailing activities by converting sustainable energy of water flow into electricity for batteries.

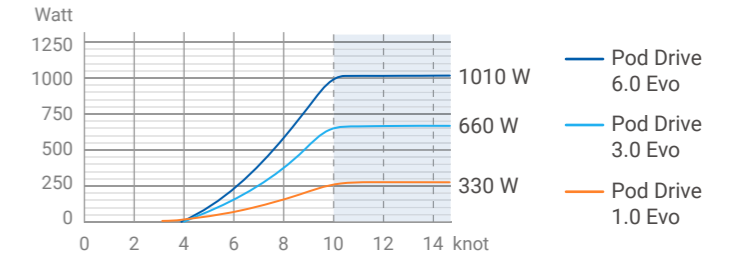

\* Pod Drive 1.0 Evo, Pod Drive 3.0 Evo and Pod Drive 6.0 Evo can drive the propeller to charge the battery (only the ePropulsion battery) through water flow when certain conditions are met (please refer to the user manual in the download center for the required conditions).

## Specs

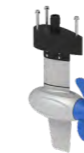

	Pod Drive 1.0 Evo	Pod Drive 3.0 Evo	Pod Drive 6.0 Evo
Power	1 kW / 3 HP	3 kW / 6 HP	6 kW / 9.9 HP
Operation Voltage	48V (Input Range 39V to 60V)		
Weight	6.2 kg / 13.7 lbs	15.3 kg / 33.7 lbs	31kg / 68.3 lbs
Static Thrust	316 N / 71 lbs	590 N / 132.6 lbs	1080 N / 242.8 lbs
Propeller RPM	1200 RPM	2300 RPM	1500 RPM
Propeller	11" x 5.8" 2-blade composite propeller	10.2" x 6.7" 2-blade composite propeller	12.6" x 8.7" 3-blade aluminum propeller / 12" x 21.3" 2-blade NAB folding propeller (optional)
Hydrogeneration	✓	✓	✓

\*The weight includes the driver unit.



# E-Series Lithium Battery

Safe and durable LiFePO4 batteries for ePropulsion motors.

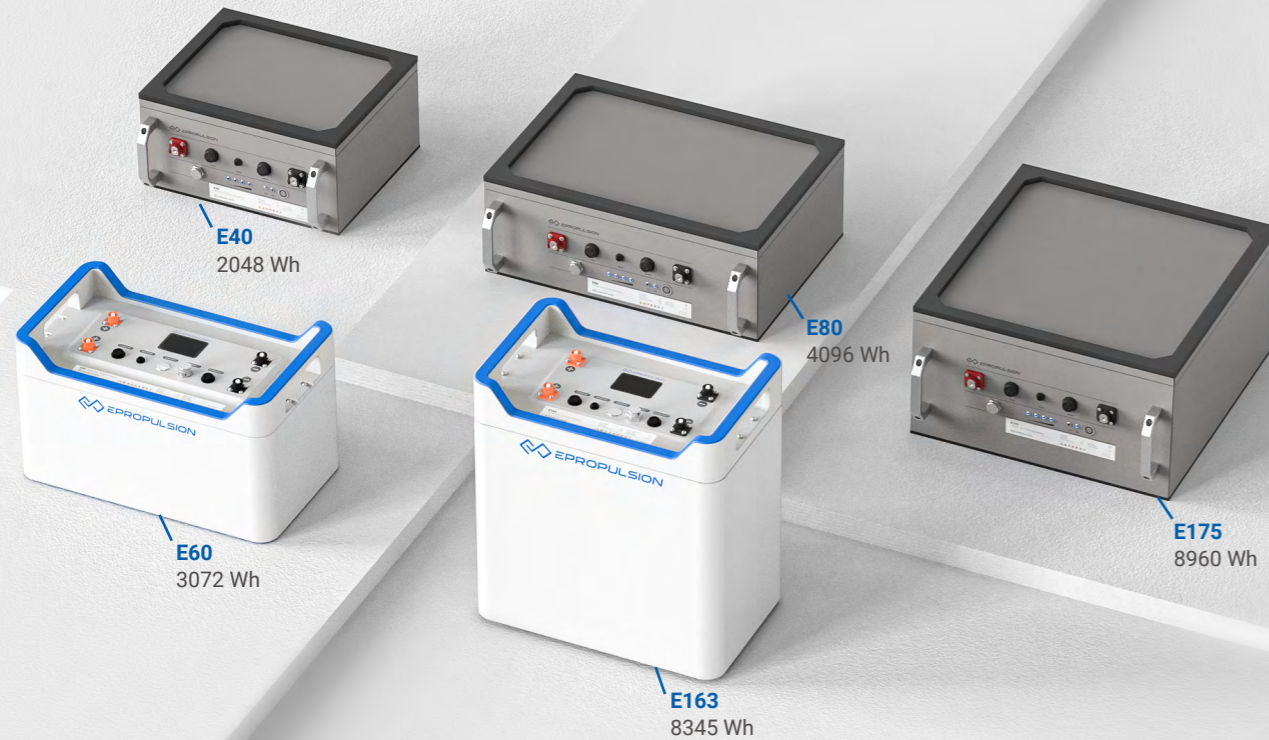

## Overview

To ensure the best customer experience by eliminating compatibility issues, it is important to supply batteries that work efficiently with ePropulsion boat motors. Our solution is the 48V E-Series battery that works seamlessly with every 48V ePropulsion motor. The lithium iron phosphate chemistry is both safe and stable. It retains over 80% capacity after 3,000 cycles. The compact size makes it flexible and easy to be use in a wide range of different boats.

## Why Choose E-Series Battery



### Competitive cost

Unit price of E40/E80/E175 is as low as \$0.5 per watt-hour.



### Long life cycles

3000 cycles at 80% DOD.



### High energy density

70% less weight and space than a normal lead-acid battery \*



### Made for ePropulsion motors

Data is synced with ePropulsion motors to allow a smart operation strategy.



### Data accuracy

ePropulsion batteries are designed for maximum efficiency, performance and safety. They allow for the use of our communication cable which brings data accuracy to the gauge and ensures a useful operating strategy for safety and performance.

\*Under equal capacity.

# Features

1C Rate Fast Charging

Waterproof to IP67

CE, UKCA, FCC, and UN38.3 Certification

## E60

3072 Wh / 48 V



### High Performance

E60 (single battery) can support Navy 3.0 Evo (6HP) full power output.

### Flexible Installation

The height of E60 battery is only 300 mm, allowing flexible installation under the boat seat or other available spaces.

### Lightweight

Features a new innovative double-layer plastic housing design weighing only 33 kg and can be safely lifted by a person.available spaces.

## E163

8345 Wh / 48 V



### High Performance

E163 (single battery) can support Navy 6.0 Evo (9.9HP) full power output.

### High Reliability

All-metal housing is more reliable, weather resistant, impact resistant and drop proof.

# Design

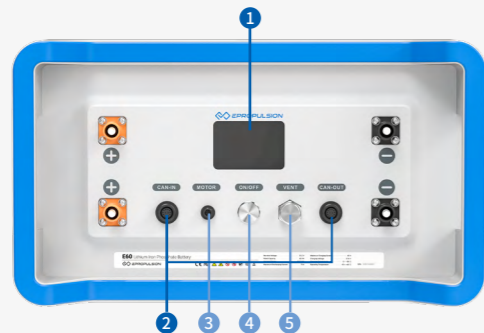

- 1 HD Screen
- 2 CAN communication port
- 3 Motor communication port
- 4 Power button
- 5 Vent valve

# Specs

	E60	E163
Capacity	3072 Wh / 60 Ah	8345 Wh / 163 Ah
Rated Voltage	51.2 V	51.2 V
Battery Life	3,000 cycles at 80% DOD	3,000 cycles at 80% DOD
Weight	33 kg	76 kg
Cut-off Voltage	41.6 V	41.6 V
Final Charging Voltage	57.6 V	57.6 V
Serial Connection	N/A	N/A
Max Continuous Discharging Current	70 A	150 A
Parallel Connection	Up to 16	Up to 16
Cell Configuration	16S4P	16S1P
Charger	E-Series battery charger	E-Series battery charger
Charging Time (220V)	One charger: 2.7 Hrs Two chargers in parallel: 1.3 Hrs	One charger: 7.2 Hrs Two chargers in parallel: 3.6 Hrs
Charging Time (110V)	One charger: 4 Hrs Two chargers in parallel: 2 Hrs	One charger: 11 Hrs Two chargers in parallel: 5.4 Hrs
Charging Temperature	0 ~ 55° C (32 ~ 131°F)	0 ~ 55° C (32 ~ 131°F)
Discharging Temperature	-10 ~ 60° C (14 ~ 140°F)	-10 ~ 60° C (14 ~ 140°F)
Shipping Classification	UN3480, Class 9, UN38.3 Certified	UN3480, Class 9, UN38.3 Certified
Approvals	CE, UKCA, FCC	CE, UKCA, FCC

# Specs



	E40	E80	E175
Capacity	2048 Wh	4096 Wh	8960 Wh
Max Continuous Discharging Current	40 A	80 A	150A
Rated Voltage	51.2 V		
Final charging voltage	57.6 V		
Cut-off voltage	41.6 V		
Battery Life	3000 Cycles at 80% DOD		
Series Connection	×	×	×
Parallel Connection	Up to 16		
Charging Time (110V)	2 Hrs	4 Hrs	One charger: 9 Hrs Two chargers in parallel: 4.5 Hrs
Charging Time (220V)	2 Hrs	3 Hrs	One charger: 6 Hrs Two chargers in parallel: 3 Hrs
Weight	28 kg / 61.7 lbs	53 kg / 116.8 lbs	87 kg / 191.8 lbs
Dimensions	42 x 39 x 20.7 cm 16.5 x 15.4 x 8.2 inches	55.5 x 44 x 21.2 cm 21.9 x 17.3 x 8.4 inches	50 x 56.5 x 27.7 cm 19.7 x 22.2 x 10.9 inches

# Design

- 1 Discharge and charge port
- 2 Motor communication port
- 3 CAN communication port
- 4 State of charge indicator lights
- 5 Power button
- 6 Removable lift handle



# E-Series Battery Charger

## Parallel Connection

Up to 8 units can be used in parallel connection. It's flexible enough to configure for a large capacity battery set.

## Wide Input Voltage Range

From 85 VAC to 265 VAC. It's available to use worldwide.



\* The charging power varies between different input voltages. At 220V, the output current is 30A. At 110V, approximately 20A.

# E Battery External Display Panel

E Battery External Display Panel is used to connect with E40 & E80 & E175 batteries to show the information of the battery.



# G102-100 New

## Lithium Iron Phosphate Battery (LiFePO4)

High-performance and durable lithium battery for electric boating, Fully Compatible with I-Series



10240 Wh / 96 V

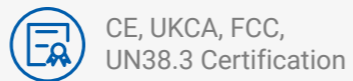
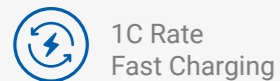

## Features



### Fully Compatible with ePropulsion Motors

Power the 96V 10kW to 40kW ePropulsion motors including the I-Series inboards.\*



### Maximum Safety

Made with LFP, the built-in intelligent battery management system (BMS) is applied to provide maximum safety for the users.



### Long Life Cycle

3,000 cycles at 80% DOD, the G102-100 lifepo4 battery powers your motors much longer than lead-acid batteries.\*\*



### High Energy Density

3 times higher energy density and 70% less weight than lead-acid batteries.\*\*



### Easy to Install

Connectors can be installed with only ONE hand, and the battery saves wiring harness connection compared to series-parallel connection of battery.



### High Reliability

All-metal housing is more reliable, weather resistant, impact resistant and drop proof.

\* G102-100 can be connected in parallel to power different ePropulsion motors.

\*\* Under equal capacity.

## Specs

Rated Voltage	102.4 V	Cell Configuration	32S1P
Cut-off Voltage	83.2 V	Charging Temperature	0°C to 55°C
Final Charging Voltage	115.2 V	Discharging Temperature	-10°C to 60°C
Serial Connection	N/A	Dimensions	680 x 500 x 300 mm (26.8 x 19.7 x 11.8 in)
Max Continuous Discharging Current	100 A	Weight	100 kg
Battery Life	3,000 cycles at 80% DOD	Shipping Classification	UN3480, Class 9, UN38.3 Certified
Parallel Connection	Up to 4 in 1 cluster. Multiple clusters are possible in the system	Communication	One CAN for ePropulsion motors / One CAN (Two ports) for parallel batteries / One CAN for charger



# Vaquita Motor 1HP

Made for Every SUP Paddler

## Overview

### Comfortable Speed

Equipped with a 300 W motor, the Vaquita takes a paddler up speed of 9 km/h or 5 knots. Traveling at that speed delivers a 70-minute runtime. Utilizing your Vaquita at half of the top speed means you'll have up to five hours of runtime.

### Enjoy More Time on the Water

The Vaquita enables you go further and explore more, assisting you when you need it. The motor allows you paddle effortlessly and gives you the power to spend more time on the water.

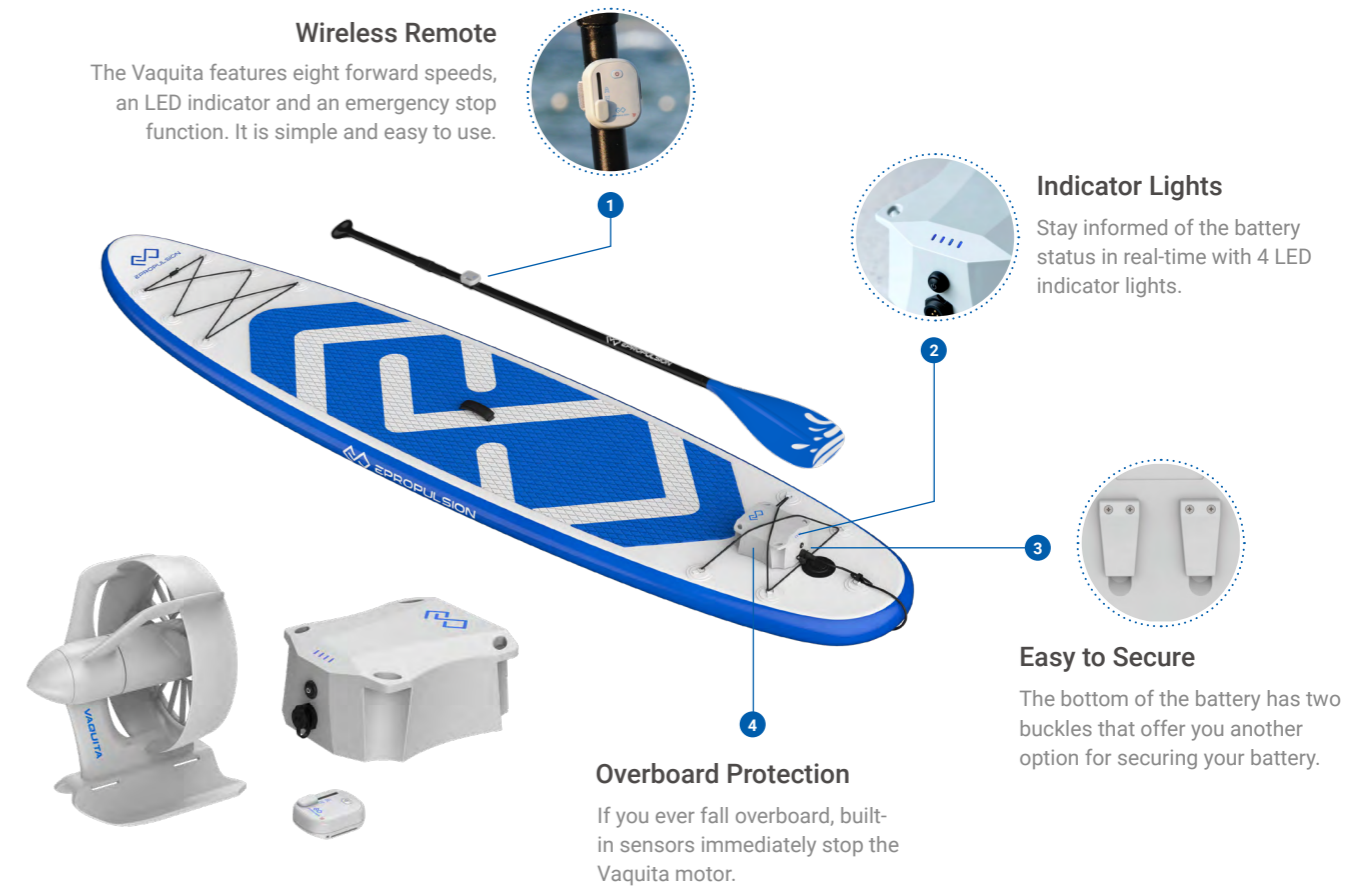



## Performance & Range

Vaquita - SUP	Speed (mph / kph)	Running Time (hh:mm)	Range (mile / km)
Slow Speed	2.6 / 4.2	8:00	20.9 / 33.6
Economical Speed	3.7 / 6	5:00	18.6 / 30
Full Speed	6.2 / 10	1:10	7.3 / 11.7

\*Data above is tested with Red Paddle 10.6 Ride MSL. The actual speed, range and running time may vary due to different external conditions.

## Specs

Running Time	70 min (full speed), 5 hr (half speed)	Battery Life	500 cycles at 80% DOD
Total Weight	4 kg	Motor Size	18.2 x 16.8 x 18.2 cm / 7.2 x 6.6 x 7.2 inches
Adapters	US fin, SUP fin, Universal adapter	Battery Size	21.6 x 17.8 x 10 cm / 8.5 x 7 x 3.9 inches
Control	Wireless remote, 8 speeds forward	Battery Ingress Protection	IP67
Battery	324 Wh, Lithium-ion		

## Lightweight & Portable





The Vaquita only weighs 4 kg. It's compact and easy to transport with our customized storage bag.



# Accessories

We strive to provide the highest quality accessories to enhance your boating experience. The full range of ePropulsion accessories and details are available at <https://www.epropulsion.com/accessories/>



## Controls

Smart Throttle	Smart Display 5"	Evo Tiller	Evo Remote Control	Evo Side Mount Control	Evo Dual Remote Control
					

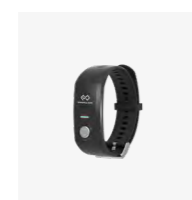

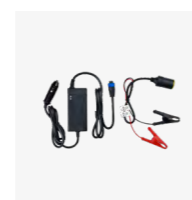

## Controls

E Battery External Display Panel	Vaquita Remote Control	Safety Wristband
		

## Charging

Spirit 1.0 Plus Charger	Spirit 1.0 Plus 12V Charger	Spirit 1.0 Plus Solar Charger
		



## Charging

Spirit 1.0 Plus Fast Charger	E Battery Charger 20A L	E Battery Charger 30A H	Foldable Solar Panel	Vaquita Charger
				

## Propellers

Spirit 1.0 Propeller

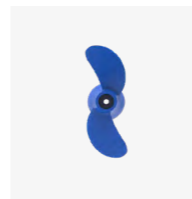
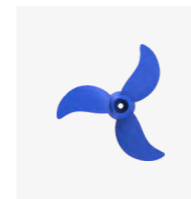
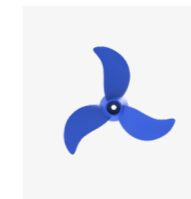

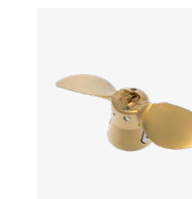
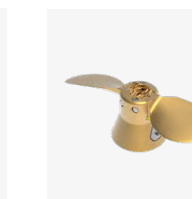

## Propellers

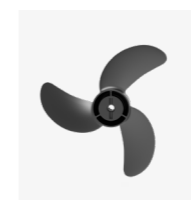
Navy 3.0 Propeller	Navy 6.0 Low Pitch Propeller	Navy 6.0 High Pitch Propeller	Navy 6.0 Evo AL Propeller	Pod 1.0 Evo Folding Propeller	Pod 3.0 Evo Folding Propeller
					

## Propellers

Pod 6.0 Evo Folding Propeller	Pod 6.0 Evo Propeller
	

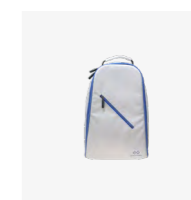
## Bags

Spirit Motor Cowling	Spirit 1.0 Outboard Bag Plus	Spirit 1.0 Battery Bag	Vaquita Carry Bag
			

# Recommended by Influencers and Specialists



## Blake Yarter

- 3 Times Georgia State Bass Total Electric Champion
- Rutledge, GA, United States
- Blake Yarter



## Charles Curtis

- Former points champion (2x) in the Jon Boat Bass Club of NC
- Wake Forest, NC, United States
- Charles Curtis

“ ePropulsion is one of the leaders of the electric outboard motor industry. The new Navy Evo 6.0 is virtually silent with smooth maneuverability and quicker hole shot. Top of the line technology sets it apart from its competitors. ”

“ I love my ePropulsion Navy 6.0 EVO electric outboard! Paired with the E175 48V lithium iron phosphate I have the confidence to outrun my opponents to the best spots and still have plenty of power to make it back on time to weigh in. It's quiet, reliable, and virtually maintenance free! ”



## Anthony Jones

- Jon Boat Fishing Specialist, Father of Two Kids
- Georgia, United States
- Anthony Jones

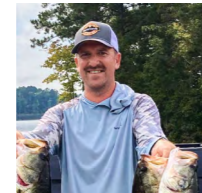

## Chris Gayton

- 2019 Georgia State Bass Total Electric Champion, Several Points Champion and Classic Champion of Small Water Angler Teams
- Cumming, Georgia, United States
- Chris Gayton

### Apply for Pro Staff Program



The ePropulsion Pro Staff Program has been developed for the fishing market from 2021. We are looking for anglers who are active on social media and enthusiastic about electric outboard motors. For our Pro Staff team, we offer excellent rebates and opportunities to try out the latest products.

Visit [www.epropulsion.com/pro-staff](http://www.epropulsion.com/pro-staff) for more information.

# Empowering Fishing Enthusiasts

## Jon Boat Bass Club of North Carolina

Headquartered in Butner NC, Jon Boat Bass Club of North Carolina (JBBCNC) is North Carolina's largest all-electric bass fishing organization, providing anglers of all skill levels the opportunity to compete. A new ePropulsion Invitational, presented by JBBCNC, has been held successfully.

“ JBBCNC is pleased to kick start the partnership with ePropulsion. The evolution of all-electric bass trails has exploded across the Southern US. Anglers looking for an economical choice as well as the love of competition have found the all-electric format to be an outstanding opportunity to compete and enjoy likeminded anglers. ”

- Jeremy Roberts, JBBCNC Committee Chair



## The Georgia Bass Total Electric Championship Invitational

The Georgia Bass Total Electric Championship Invitational (GA Bass TEC) is one of the largest electric only jon boat fishing tournaments in Georgia State. Top anglers from 9 major clubs and 36 teams participated in the 2022 competition.

“ When the electric only bass fishing sport originated it was typical to achieve speeds of three to four miles per hour. Now it may not seem drastic but these ePropulsion motors are reaching speeds nearly four times higher depending on the boat setup. The range of ePropulsion's motors when paired with lithium battery packs are much greater than the competition. Anglers can go longer distances at higher speeds with ePropulsion; leaving others in their wake. ”

- Merrick McClure, Director, ePropulsion GA Bass TEC





# Online ePropulsion Owner Community



We connect and engage ePropulsion owners from all around the world through the Official ePropulsion Outboard Owners Facebook Group.

Join us and share your exciting electric boating moments with the worldwide ePropulsion customers. You will also get fast responses when you have questions about your ePropulsion products as well as staying updated on product upgrade and promotions.

Most active members will be recognized and be rewarded with souvenirs such as branded apparel and headwear.



Search [Official ePropulsion Outboard Owners](#) on Facebook



## Ordering Information

### MOTORS

PART NO	PRODUCT	DESCRIPTION
<b>SPIRIT</b>		
SP-0000-X1	Spirit 1.0 Plus Extra Shortshaft	3 HP direct drive electric outboard motor, including a 1276 Wh battery, an integrated tiller and a charger. Shaft length 52.5 cm / 20.7 inches.
SP-0000-S1	Spirit 1.0 Plus Shortshaft	Same as above with different shaft length 62.5 cm / 24.6 inches.
SP-0000-L1	Spirit 1.0 Plus Longshaft	Same as above with different shaft length 75 cm / 29.5 inches.
SP-1111-X1	Spirit 1.0 Plus Extra Shortshaft w/o Battery	3 HP direct drive electric outboard motor, including a tiller and a charger. Battery is excluded. Shaft length 52.5 cm / 20.7 inches.
SP-1111-S1	Spirit 1.0 Plus Shortshaft w/o Battery	Same as above with different shaft length 62.5 cm / 24.6 inches.
SP-1111-L1	Spirit 1.0 Plus Longshaft w/o Battery	Same as above with different shaft length 75 cm / 29.5 inches.
SE-TTTT-S0	Spirit 1.0 Evo Shortshaft	3 HP direct drive electric outboard motor featuring hydrogeneration, including a 1276 Wh battery, a detachable tiller and a charger. Shaft length 62.5 cm / 24.6 inches.
SE-TTTT-L0	Spirit 1.0 Evo Longshaft	Same as above with different shaft length 75 cm / 29.5 inches.
SE-RRRR-S0	Spirit 1.0 Evo Remote Shortshaft	3 HP direct drive electric outboard motor featuring hydrogeneration, including a 1276 Wh battery, a remote control, a charger and a remote kit. Shaft length 62.5 cm / 24.6 inches.
SE-RRRR-L0	Spirit 1.0 Evo Remote Longshaft	Same as above with different shaft length 75 cm / 29.5 inches.
SE-1111-S0	Spirit 1.0 Evo Motor Body Shortshaft	3 HP direct drive electric outboard motor featuring hydrogeneration. Battery and controller are excluded. Shaft length 62.5 cm / 24.6 inches.
SE-1111-L0	Spirit 1.0 Evo Motor Body Longshaft	Same as above with different shaft length 75 cm / 29.5 inches.
SE-R999-00	Spirit 1.0 Evo Remote Kit	This remote kit helps you turn a Spirit 1.0 Evo motor into a remote version that works with a steering wheel.
<b>NAVY</b>		
NE-3000-S0	Navy 3.0 Evo Shortshaft	6 HP direct drive electric outboard motor featuring hydrogeneration. Battery, controller and charger are excluded. Shaft length 64 cm / 25.2 inches.
NE-3000-L0	Navy 3.0 Evo Longshaft	Same as above with different shaft length 76.5 cm / 30.1 inches.
NE-6000-S0	Navy 6.0 Evo Shortshaft	9.9 HP direct drive electric outboard motor featuring hydrogeneration. Battery, controller and charger are excluded. Shaft length 64 cm / 25.2 inches.
NE-6000-L0	Navy 6.0 Evo Longshaft	Same as above with different shaft length 76.5 cm / 30.1 inches.

PART NO	PRODUCT	DESCRIPTION
<b>POD</b>		
P1-0000-E0	Pod Drive 1.0 Evo	3 HP direct drive electric pod drive motor featuring hydrogeneration. Battery, controller and charger are excluded.
P3-0000-E0	Pod Drive 3.0 Evo	6 HP direct drive electric pod drive motor featuring hydrogeneration. Battery, controller and charger are excluded.
P6-0000-E0	Pod Drive 6.0 Evo	9.9 HP direct drive electric pod drive motor featuring hydrogeneration. Battery, controller and charger are excluded.

<b>VAQUITA</b>		
VA-0000-00	Vaquita SUP Motor	1 HP direct drive electric SUP motor, including a 324 Wh battery, a remote control and a charger.

<b>I SERIES INBOARD</b>		
TBD	I-10	10 kW direct drive electric inboard motor.
TBD	I-20	20 kW direct drive electric inboard motor.
TBD	I-40	40 kW direct drive electric inboard motor.

## BATTERIES

PART NO	PRODUCT	DESCRIPTION
SP-B000-02	Spirit Battery Plus	1276 Wh / 48V lithium battery for Spirit 1.0 Plus, Spirit 1.0 Evo and Spirit 1.0R Evo. Lightweight, safe and floatable.
EB-0040-00	E40 Battery	2048 Wh / 48V LiFePO4 battery with 3000 cycles of battery life. High energy density in a compact size. Safe and durable.
EB-0060-00	E60 Battery	3072 Wh / 48V LiFePO4 battery with 3000 cycles of battery life. High energy density in a compact size. Affordable, safe and durable.
EB-0080-00	E80 Battery	4096 Wh / 48V LiFePO4 battery with 3000 cycles of battery life. High energy density in a compact size. Safe and durable.
EB-0163-00	E163 Battery	8345 Wh / 48V LiFePO4 battery with 3000 cycles of battery life. High energy density in a compact size. Affordable, safe and durable.
EB-0175-00	E175 Battery	8960 Wh / 48V LiFePO4 battery with 3000 cycles of battery life. High energy density in a compact size. Safe and durable.
GB-0100-00	G102-100 Battery	10240 Wh / 96V LiFePO4 battery with 3000 cycles of battery life. High energy density in a compact size. Affordable, safe and durable.

PART NO	PRODUCT	DESCRIPTION
VA-B000-00	Vaquita Battery	324 Wh / 24V lithium battery for Vaquita SUP motor. Lightweight and compact.

## CONTROLS

PART NO	PRODUCT	DESCRIPTION
NE-TC00-00	Evo Tiller	Detachable tiller with integrated display monitoring real-time motor / battery status, for Spirit Evo models and Navy Evo models.
NE-RC00-00	Evo Remote Control	Wireless remote controller with integrated display monitoring real-time motor / battery status, for Spirit 1.0R Evo, Navy Evo models and Pod Evo models.
NE-SM00-00	Evo Side Mount Control	Smart side mount controller with independent display monitoring real-time motor / battery status, for Spirit / Navy / Pod Evo models.
NE-DR00-00	Evo Dual Remote Control	Remote control for twin installation of Spirit / Navy Evo motors. Independent display monitors real-time status of power and each motor.
XS-RC00-00	Smart Throttle	Display panel, for I-series Inboard motor.
XS-DP00-00	Smart Display 5"	Wired remote controller, for I-series Inboard motor.
VA-RC00-00	Vaquita Remote Control	Wireless remote control for Vaquita SUP motor. 8 forward speeds. Overboard protection.

## ACCESSORIES

PART NO	PRODUCT	DESCRIPTION
<b>CHARGERS &amp; SOLAR PANEL</b>		
VA-C000-00	Vaquita Charger	180 watts charger for Vaquita Battery. Input voltage (AC): 100 V ~ 240 V. Max output voltage (DC): 25.2 V.
SP-C001-00	Spirit 1.0 Plus Charger	180 watts charger for Spirit Battery Plus. Input voltage (AC): 100 V ~ 264 V. Max output voltage (DC): 52.2 V.
SP-C002-00	Spirit 1.0 Plus 12V Charger	70 watts DC / DC charger, allowing the Spirit 1.0 Plus Battery to be charged from a 10 V ~ 30 V power source.
SP-C003-00	Spirit 1.0 Plus Solar Charger	180 watts solar charger, allowing the Spirit Battery Plus to be charged with solar energy (solar panel excluded).
SP-C004-02	Spirit 1.0 Plus Fast Charger	520 watts charger, taking 3 hours to charge a Spirit Battery Plus from empty to full. Input voltage (AC): 100 ~ 240 V.
EC-0030-21	E Battery Charger 30A H	For E-Series battery. Max output current (220V): approx. 30A. Parallel connection: max 8 units.
EC-0020-12	E Battery Charger 20A L	For E-Series battery. Max output current (110V): approx. 20A. Parallel connection: max 8 units.
FS-P000-00	Foldable Solar Panel	100 watts foldable solar panel, portable and efficient, with plug & play waterproof connectors, designed for Spirit Battery Plus.

PART NO	PRODUCT	DESCRIPTION
<b>CABLES</b>		
00-0601-04	Communication Cable 0.5 m	Connect a motor and a controller or a motor and an E-series battery for more accurate data transmission.
00-0601-01	Communication Cable 5 m	Connect a motor and a controller or a motor and an E-series battery for more accurate data transmission.
00-0601-03	Communication Extension Cable 5 m	Extend the 5m communication cable for extra 5 meters to allow wired operation from a longer distance.
00-0601-10	E Battery Communication Cable 1.5 m	A 1.5m communication cable used for parallel connection between E40 & E80 & E175 batteries.
00-0601-11	E Battery Communication Extension Cable 2 m	A 2m communication cable that extends the parallel connection distance between E40 & E80 & E175 batteries.
EB-AC02-00	E Battery Remote Switch 5 m	This switch with a 5m cable allows you to switch on/off paralleled E40 & E80 & E175 batteries in a distance. It connects to the CAN-IN port on an E40 & E80 & E175 batteries.
EB-AC01-00	E-Series Battery Communication Terminator	This is a required item for the parallel connection of E40 & E80 & E175 batteries. It connects to the CAN-IN port on the master battery.
EB-AC01-01	Battery Communication Terminator	This is a required item for the parallel connection of E60 & E163 & G Series batteries. It connects to the CAN-IN on the master battery and CAN-OUT port on the end battery.
EB-AC02-01	Battery Remote Switch 5 m	This switch with a 5m cable allows you to switch on/off paralleled E60 & E163 & G series batteries in a distance. It connects to the CAN-IN port on an E-series battery.
EB-AC05-00	Battery Comm Cable T Connector	A CAN T connector with one male connector and two female connectors, allowing you to connect both the controller and the E60 & E163 batteries to an ePropulsion motor.
EB-CP09-00	E Battery Bridging Cable 0.15 m (Positive & Negative)	For E60 & E163 batteries parallel and series connection.
EB-CP01-00	E Battery Bridging Cable 0.45 m (Positive & Negative)	For E60 & E163 batteries parallel and series connection.
EB-CP02-00	E Battery Bridging Cable 1.5 m (Positive & Negative)	For E60 & E163 batteries parallel and series connection.
EB-CP03-00	E Battery Bridging Cable 5 m (Positive & Negative)	For E60 & E163 batteries parallel and series connection.
EB-CP04-00	E Battery Output Cable 1.5 m (Positive & Negative)	For E60 & E163 batteries and motor connection.
EB-CP05-00	E Battery Power Cable Connector	For E60 & E163 batteries and motor connection.
EB-CP06-00	Battery Communication Cable 0.5 m	For E60 & E163 & G Series battery parallel and series connection.
EB-CP07-00	Battery Communication Cable 1.5 m	For E60 & E163 & G Series battery parallel and series connection.
EB-CP08-00	Battery Communication Cable 5 m	For E60 & E163 & G Series battery parallel and series connection.

PART NO	PRODUCT	DESCRIPTION
EB-AC03-00	Bus Bar 200A	For 48V battery and other devices such as charger, MPPT, DCDC connection.
EB-AC04-00	DCDC 48V-12V 60W	60W DCDC is used to convert E-Series battery from 48V to 12V for powering other 12V devices.
00-0601-08	Spirit External Battery Cable 1.5 m	This cable allows you to connect the Spirit 1.0 Plus/Evo motor with a 48V E-Series Battery to extend range.
00-0601-09	Spirit 1.0 Plus Extension Power Cable 2 m	It connects the Spirit Battery Plus and the Spirit 1.0 Plus/Evo motor, allowing you to place the battery 2 meters from the motor.
00-0601-12	Y Type Communication Cable 0.3 m	A communication cable with one male connector and two female connectors, allowing you to connect both the controller and the E-Series batteries to an ePropulsion motor.
00-0601-25	Connection Cable for Pod 1.0 Evo and Spirit Battery Plus 1 m	It connects the Spirit Battery Plus and the Pod Drive 1.0 Evo.
00-0601-28	0.5m Battery Bridging Cable	For E40 & E80 & E175 batteries parallel and series connection.
00-0601-29	1m Battery Bridging Cable	For E40 & E80 & E175 batteries parallel and series connection.
00-0601-30	2m Battery Bridging Cable	For E40 & E80 & E175 batteries parallel and series connection.
<b>STEERING</b>		
00-0800-02	Dual Motor Link Arm	For dual-engine steering.
<b>PROPELLERS, SKEGS, ANODES</b>		
S1-M001-00	Spirit 1.0 Propeller	11" x 5.8" 2-blade composite propeller, applies to Spirit 1.0 Plus/Evo.
SE-TB01-00	Spirit 1.0 Evo Clamp Anode	Applies to Spirit Plus manufactured since 2022 and Spirit Evo.
S1-TB02-05	Spirit 1.0 Clamp Base Anode	Applies to all Spirit outboards.
SP-M013-00	Spirit 1.0 Plus Motor Anode	Applies to Spirit 1.0 Plus/Evo.
SP-M012-00	Spirit 1.0 Plus Shaft Anode	Applies to Spirit 1.0 Plus/Evo.
S1-TB03-06	Spirit 1.0 Trapezoidal Anode	Applies to Spirit 1.0 Plus/Evo.

PART NO	PRODUCT	DESCRIPTION
<b>PROPELLERS, SKEGS, ANODES</b>		
N6-AP00-E0	Navy 6.0 Evo Anticavitation Plate	Avoid vaporized air caused by water flow disturbances. Made of high-strength aluminum alloy.
N6-TB11-00	Navy Clamp Anode	Sacrificing itself to protect the surface of the outboard from corroding, applies to Navy Evo, double inner-side of clamp.
N6-AP00-00	Navy Anticavitation Plate	Avoid vaporized air caused by water flow disturbances. Made of high-strength aluminum alloy.
N6-LU01-00	Navy Anode	Sacrificing itself to protect the surface of the outboard from corroding, applies to Navy Evo, outside of the propeller shaft.
P6-M013-00	Navy Evo Anode	Applies to Navy 6.0 Evo & Pod 6.0 Evo.
N3-LU05-00	Navy 3.0 Propeller	10.2" x 6.7" 2-blade composite propeller.
N6-LU02-00	Navy 6.0 Low Pitch Propeller	13.4" x 8.5" 3-blade composite propeller.
N6-LU12-00	Navy 6.0 High Pitch Propeller	12.6" x 10.8" 3-blade composite propeller.
N6-LU01-E0	Navy 6.0 Evo AL Propeller	12.6" x 8.7" 3-blade aluminum propeller.
P6-M001-00	Pod 6.0 Evo Propeller	12.6" x 8.7" 3-blade aluminum propeller.
P6-LU01-00	Pod 6.0 Evo Folding Propeller	12" x 21.3" 2-blade NAB folding propeller.
P3-LU01-E0	Pod 3.0 Evo Folding Propeller	9.96" x 6.34" 2-blade NAB folding propeller.
P1-LU01-E0	Pod 1.0 Evo Folding Propeller	9.96" x 6.34" 2-blade NAB folding propeller.
P1-LU02-E0	Pod 1.0 Evo Folding Propeller Anode	Applies to Pod 1.0 Evo Folding Propeller.
P3-LU02-E0	Pod 3.0 Evo Folding Propeller Anode	Applies to Pod 3.0 Evo Folding Propeller.

PART NO	PRODUCT	DESCRIPTION
<b>EXTRAS</b>		
VA-BG00-00	Vaquita Carry Bag	Transport and store a complete Vaquita kit. Dust-resistant and washable.
S1-BG00-01	Spirit 1.0 Bag Set Plus	Made for easy transportation and storage of a Spirit outboard and a Spirit battery.
S1-BG01-01	Spirit 1.0 Outboard Bag Plus	Transport and store a Spirit motor. Dimension: 48.8 x 7.8 x 16.5 inches / 124 x 20 x 42 cm.
S1-BG02-00	Spirit 1.0 Battery Bag	Transport and store a Spirit battery. Dimension: 11.8 x 7.8 x 16.5 inches / 30 x 20 x 42 cm.
SP-M005-00	Spirit Motor Cowling	If a Spirit motor works with an E-Series battery, the original Spirit battery is removed. This cowling is put on the top for decoration purpose.
S1-TH02-00	Kill Switch Assy.	Shut down the motor upon the removal of this magnetic kill switch. A safety lanyard is included.
NE-SW00-00	Safety Wristband	IP67 wireless wristband works with Evo Tiller / Evo Remote Control. Shut down the motor in accidents. Max connection up to 8 units.
EB-DP00-00	E Battery External Display Panel	Display panel for E40 & E80 & E175 batteries.
S1-BA01-00	Spirit Battery Power Output Set	It is working with the Spirit battery activator to power other appliances.
SM-TH03-00	Side Mount Kill Switch	Shut down the motor upon the removal of this magnetic kill switch. A safety lanyard is included. Applies to Side Mount Control.
NE-DR02-00	Dual Remote Kill Switch	Shut down the motor upon the removal of this magnetic kill switch. A safety lanyard is included. Applies to Dual Remote Control.
00-0800-02	Dual Motor Link Arm 700-900 mm	For dual-engine steering.
00-0800-03	Dual Motor Link Arm 400-600 mm	For dual-engine steering.
SR-CM04-00	Link Arm Lock	For locking the steering link arm.

Follow ePropulsion on

